



Chargers « Flash »

SCW35 1A-35A
SCW150 5A-150A

FLASH SERIES

Battery Charger / Battery Support

User Manual

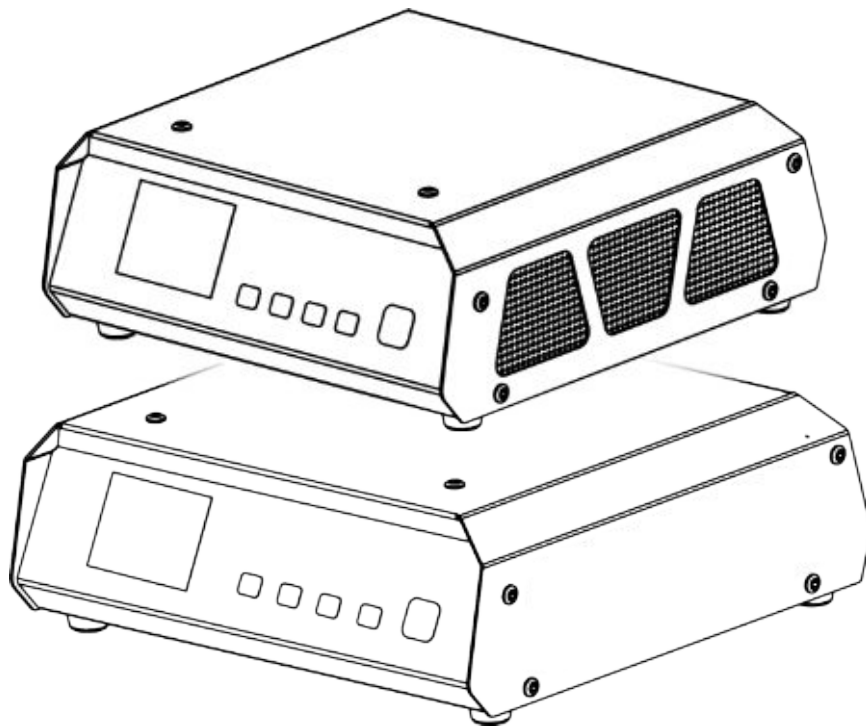

UK
CA

CE

FC



SWISS
QUALITY

F35 (12/24V)
F150 (12V)

GENERAL INFORMATION

PRODUCT OVERVIEW:

This series of Flash chargers are designed for industrial usage in the modern workshop environment. They can be used for a range of applications from Battery Charging & Maintenance, Diagnostics & Power Supply, Showroom Battery Support and Battery Testing. They are compatible with different Lead/Acid chemistries as well as new LiFePo4 lithium batteries. In Diagnostic mode they can output constant voltage for various vehicle service operations such as fault finding, module re-programming and battery support during other operations. In the Showroom mode they can supply the current needed by a vehicle in demonstration mode allowing all of the features of the vehicle to be shown without draining the battery. The Test function can be used to check the condition of the vehicle's starting battery as well as the starter motor. The Flash chargers also feature a self-calibration mode in the event of any component changes.

SMART BATTERY CHARGER, ADJUSTABLE POWER SUPPLY, BATTERY MAINTAINER & TESTER

MAIN FEATURES:

- Advanced SMPS technology and patented battery charging and reconditioning technology.
- Power factor correction (PFC)
- Automatic Multi-step Charging mode
- Ability to properly charge multiple battery types: Flooded, AGM, EFB, GEL and Lithium (LiFePo4) batteries
- Multiple rates of charge and charging parameters to suit various battery capacities.
- Automatic detection of: short circuited battery cells, sulphated batteries. Automatic reconditioning and cell balancing.
- Diagnostic mode featuring constant voltage output.
- Showroom mode ensures power compensation for a vehicle in demonstration mode.
- Modern Color TFT display and intuitive & user interface.
- Automatic restart function in both Charge and Showroom mode following a cut in AC power. Auto-detect.
- Charge and Showroom mode settings automatically memorized by Auto-detect system.
- DC Output charging cable integrity check function.
- Firmware update compatible through USB port.
- Can be sat, permanently wall mounted or hung where necessary.

CHARACTERISTIC:

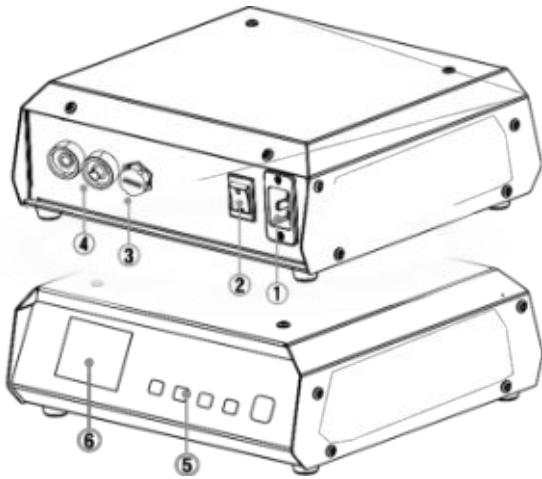

Fig-1

1. AC Input Socket
2. Main On/Off switch
3. USB Firmware update port
4. DC Output Sockets (+/-)
5. Menu Navigation Keys
6. TFT Display

IMPORTANT SAFETY INSTRUCTIONS:

SAVE THESE INSTRUCTIONS, THIS MANUAL CONTAINS IMPORTANT SAFETY AND OPERATING INSTRUCTIONS KEEP IT WITH OR NEAR THE CHARGER AT ALL TIMES.

1. **WARNING** - RISK OF EXPLOSIVE GASES WORKING IN VICINITY OF A LEAD-ACID BATTERY IS DANGEROUS. EXPLOSIVE GASES DEVELOP DURING NORMAL BATTERY OPERATION. IT IS IMPORTANT THAT EACH TIME BEFORE USING YOUR CHARGER, YOU READ THIS MANUAL AND FOLLOW THE INSTRUCTIONS EXACTLY.

This device has been designed for trained professionals and according to the codes of practice valid at that time. It is safe to operate, but please make sure to read and understand this user manual beforehand. It can be dangerous if it is used by non-professionally trained personnel or in an incorrect way. The manufacturer cannot be held responsible for the incorrect use of this device. Please follow these steps for maximum safety.

- 1.1 Always wear safety equipment: Goggles, gloves, ear protection and appropriate attire.
- 1.2 Only use accessories or attachments approved by the manufacturer.
- 1.3 Modifications or alterations to this device are forbidden. Repairs and service can only be performed by an official authorized center. Damaged cords, cables, chargers or devices must be immediately fixed or replaced.
- 1.4 Always use this device in a well-ventilated area. Never use in potentially explosive areas or near flammable materials.
- 1.5 Avoid short circuits and never have the clamps touch each other, or any metal part at the same time.
- 1.6 This device is not meant to be used by people (including children) with reduced physical or mental capabilities, or by people without experience or that have not been professionally trained. Please keep this device out of reach of children to make sure they do not play with it.
- 1.7 To reduce risk of a battery explosion, follow these instructions and those published by the battery manufacturer and/or the manufacturer of any equipment you intend to use or have nearby. Review all the cautionary markings.
- 1.8 Do not expose charger to rain, snow, or liquids. Never submerge in water, burn or throw away in domestic waste.
- 1.9 Safety equipment, such as fire extinguisher or water to rinse eyes, should always be nearby. Also make sure someone else is nearby in case of emergency.

- 1.10 If battery acid enters in contact with your eyes, skin or clothing, wash immediately with soap and water. If acid enters in contact with your eyes, immediately flush them with running cold water for at least 10 minutes and get medical attention immediately.
- 1.11 Remove personal metal items when working near engines/motors & batteries.
- 1.12 Always read the vehicle's user manual before connecting any charger to the vehicle or its battery.
- 1.13 Do not attempt to charge a marine (boat) battery while the boat is on or near the water. A boat must be on a trailer and located indoors before attempting to charge its battery(s). The boat manufacturer's instructions must be followed exactly.
- 1.14 To reduce risk of damage to the electric plug and cord, pull the plug rather than the cord when disconnecting the charger
- 1.15 An extension cord should not be used unless absolutely necessary. Use of improper extension cord could result in a risk of fire and electric shock. If an extension cord must be used, make sure that the pins on plug of the extension are the same as on the charger, and that the extension cord is properly wired and in good electrical condition. The wire size must be large enough and related to the A.C. amperage rating of the charger.
- 1.16 If this device has been dropped, is damaged or is leaking, please have it controlled right away by an authorized agent.
- 1.17 Appliances containing batteries which contain hazardous materials for the environment:
- Batteries contain lead and dilute sulfuric acid. Dispose of the battery in accordance with federal, state and local regulations. Do not dispose of the battery in a landfill, lake or natural environment. It must be recycled properly.
 - Scrap and replace the VRLA battery at or before the time indicated on the battery or in the user's manual. Usage beyond the required time of service can cause fluid leakage due to damages to the container, or cause fire due to power leakage.
- 1.18 When the battery charger is charging a vehicle's battery, the following steps should be done:
- The battery terminal that is not connected to the chassis has to be connected first. The other connection is to be made to the chassis, away from the battery and fuel line. The battery charger is then to be connected to the supply mains.
 - After charging, disconnect the battery charger from the supply mains, and then remove the chassis connection before the battery connection, in this order.
- 1.19 NEVER smoke, allow a spark or flame in vicinity of battery or engine.
- 1.20 Do not use the battery charger for recharging dry-cell or non-rechargeable batteries that are commonly used with home appliances. These batteries may burst and cause personal injuries and/or property damages.
- 1.21 NEVER charge an inappropriate type of battery, or an inappropriate voltage.
- 1.22 Always store the clamps correctly after each use.
- 1.23 - Battery acid and gases can be dangerous, never touch or inhale them. Be careful when operating inside engine bays. Moving parts may cause injuries. Never use this device to start or recharge a frozen (very cold) battery. It could be very dangerous.
- 1.24 - Always check the voltage of the vehicle's battery before trying to recharge it.
- 1.25 - Please recycle this device, batteries and their packaging properly. Always keep the device at room temperature (15-25°C).



2 PREPARING TO CHARGE

- 2.1 If it is necessary to remove the battery from the vehicle before charging, ensure that the vehicle is off before disconnecting the battery. When disconnecting, always remove the negative battery connection first. Ensure that the environment around the battery and charger is well ventilated.
- 2.2 Clean the battery terminals (Be careful to keep any dislodged corrosion away from your skin and eyes). If needed, add distilled water to each battery cell until the acid reaches the level specified by the battery manufacturer. This helps purge excessive gas from the cells. Do not overfill. Carefully read and follow the vehicle and battery manufacturer's recharging instructions. Specific precautions, such as removing or not removing the cell caps while charging and recommended rates of charge should be followed.
- 2.3 Determine the voltage of the battery, according to the vehicle's or battery manufacturer and ensure it matches the output characteristics of the battery charger.

3 CHARGER LOCATION AND CONNECTION PRECAUTIONS

- 3.1 Place the charger as far away from battery as the cables permit. Never place the charger directly above the battery being charged, or vice versa. Gases from the battery will damage the charger, never allow battery acid to drip on the charger.
- 3.2 Do not operate the charger in a closed area or without adequate ventilation.
- 3.3 The charger must be disconnected from the AC supply before connecting or disconnecting from a battery.
- 3.4 Never allow the clamps or output terminals to touch each other creating a short circuit.
- 3.5 If problems arise connecting the output leads, solicit the aid of your Dealer to find a solution for your application.

4 STEPS WHEN A BATTERY IS INSTALLED INSIDE THE VEHICLE.

A SPARK NEAR A BATTERY MAY BE DANGEROUS. HOW TO REDUCE THIS RISK:

- 4.1 Ensure that any cables are far from moving parts or pinch points when using the charger.
- 4.2 Stay clear of fan blades, belts, pulleys, and any other parts that could cause personal injury.
- 4.3 Ensure that the polarity of the connections is correct: the POSITIVE (Red, POS., P, +) post usually has a larger diameter than the NEGATIVE (Black, NEG., N, -). If you are unsure, use a voltmeter to check the terminal polarities.
- 4.4 Determine which post of battery is grounded (connected) to chassis. For negative-grounded vehicles, first connect the POSITIVE clamp to the POSITIVE (POS., P, +) ungrounded terminal of battery. Then connect the NEGATIVE clamp to the vehicle's chassis or engine block away from the battery.
- 4.5 Do not connect the charger to any part of the vehicle other than the battery terminals or negative ground post.
- 4.6 Connect charger AC supply cord to electrical outlet
- 4.7 When disconnecting charger, turn the charger off, disconnect the charger from the AC power, remove the clamp from the chassis, and then remove the clamp connected to the battery terminal. See operating instructions for duration of charge information.

5 FOLLOW THESE STEPS WHEN THE BATTERY IS OUTSIDE THE VEHICLE.

WARNING: SPARKS NEAR A BATTERY MAY CAUSE EXPLOSIONS.

- 5.1 Check the polarity of the battery terminals. (+ / -)
- 5.2 Connect the Positive clamp to the Positive battery terminal.
- 5.3 Position yourself as far away from battery as possible and connect the Negative clamp to the Negative battery terminal.
- 5.4 Do not face the battery when completing the connections.
- 5.5 Connect the AC supply cable to the electric socket and turn the charger on.
- 5.6 When disconnecting the charger, complete the steps in reverse.

OPERATING INSTRUCTIONS

1 BROWSING THE MAIN INTERFACE

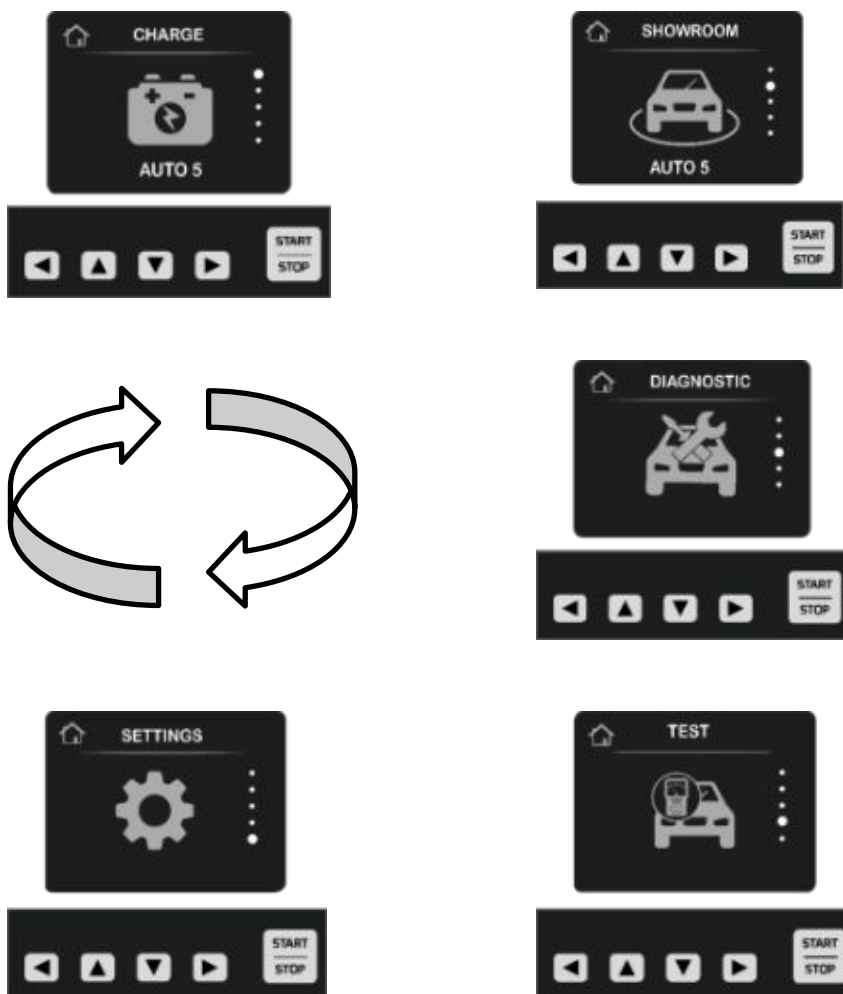

2 MAIN INTERFACE MODE

The device provides 5 Main Interface with the following modes:

SETTINGS MODE → CHARGE MODE → SHOWROOM MODE → DIAGNOSTIC MODE → TEST MODE

Press   to enter the Main menu or return to the previous menu.

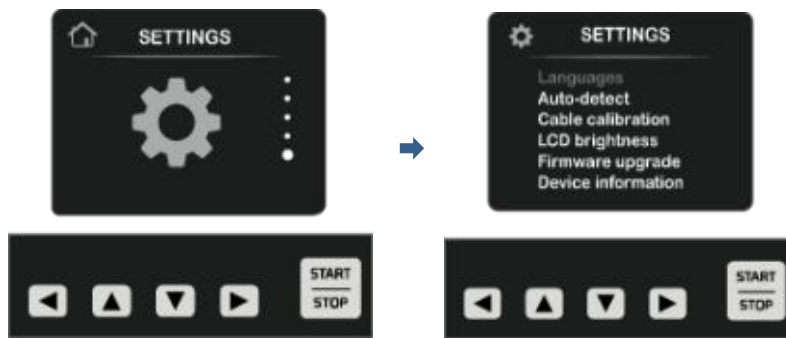

Press   to cycle between the various modes and settings

3 SETTINGS:



Operation:

Step 1: Press  to ENTER the **SETTING** submenu.

Step 2: Press   to Select the desired setting.

Step 3: Press  to **CONFIRM** and proceed into the desired settings menu.

Settings Displayed:

LANGUAGE; AUTO-DETECT; CABLE CALIBRATION; LCD BRIGHTNESS; FIRMWARE UPDATE; DEVICE INFO

LANGUAGE SETTINGS

Operation:

Step1: Press  to ENTER the **LANGUAGE** Submenu.

Step2: Press   to Select the desired language.

Step3: Press  to Confirm the selected language.

Languages Displayed: English; French, Germany, Spanish, Russian, Italian, Dutch

AUTO-DETECT SETTING

Operation:

Step1: Press  to ENTER the **AUTO - DETECT** Submenu.

Step2: Press   to Select the desired setting.

Step3: Press  to Confirm the **AUTO - DETECT** setting.

Settings Displayed: CHARGE ON / OFF; SHOWROOM ON / OFF

If the **AUTO-DETECT** is ON, the charger will automatically restart the **CHARGE** or **SHOWROOM** modes following an AC power cut. Please see the **CHARGE MODE** or **SHOWROOM MODE** introduce in the sections 4. and 6.

CABLE CALIBRATION SETTING

Operation:

Step1: Press  to ENTER the **CABLE CALIBRATION** Submenu.

Step2: Connect the positive and negative clamps together ensuring a solid connection.

Step3: Press the **Start/Stop** button. The charger will automatically test the output cables.

Settings Displayed:

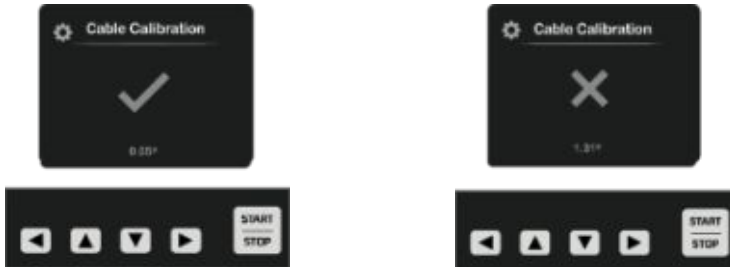

Important: If the DC output cables need to be replaced, consult your distributor to order a replacement set. Only DC output cables approved by the manufacturer can be used with this device, once the cables have been replaced, they must be calibrated as shown above.

LCD BRIGHTNESS SETTING

Operation:

Step1: Press  to ENTER the **LCD BRIGHTNESS** Submenu

Step2: Press  to Set the desired brightness level.

The default setting is set at 50%.



FIRMWARE UPDATE SETTING

Operation:

Do not attempt to update the Firmware with any other updates than those released by the manufacturer. Critical damage can occur if unapproved updates are applied or updates are applied incorrectly.

Step1: Download the firmware update onto an empty USB storage device. Connect the storage device to the Charger through the USB port.

Step2: Press  to Enter the **Firmware update** submenu

Step3: Press   to set the four-digit code provided by the manufacturer to unlock the update mode.

Step4: Press the **Start/Stop** button. The device will automatically update the firmware version.

Step5: Once the firmware update is complete, press any key to restart the charger with the updated software.

DEVICE INFORMATION

Operation:

Press  to Enter the **Device information** display:

Display: **Firmware version, the TFT firmware version, the Product rating, etc.**

4 CHARGE MODE:

The charger's advanced software is optimized to correctly and completely charge a wide variety of battery types and chemistries, including lead acid (Flooded, AGM, EFB, GEL) and Lithium (LiFePo4) starting batteries from 20Ah to 1200Ah.



Once the **CHARGE Mode** is selected, the charging voltage, battery type and charging current can be entered.

Ensure that the input parameters (nominal voltage, battery type, charging current) are correct for the battery that you are attempting to charge, that they meet the battery manufacturer's specifications and that you have read the battery's recharging instructions. Failure to respect the battery specifications may result in damage to the charger, the battery, the vehicle, property, or personal injury.

Charging Mode operation



Step 1: Press   to **ENTER** or **EXIT** the charge mode

Step 2: Press   to Select the desired parameter

Step 3: Press  to **Start** or **Stop** the charging process.



Displayed values during charging:

Charging Percentage: indicates percentage of charge (%).

Current: displays the charging current (A)

Voltage: displays the charging voltage (V)

Ah: displays the Amp-hours recharged.

Time: displays the duration of charge

1.1 Smart Charging Process:

Important: Ensure the selected mode and parameters match the type of battery you are attempting to charge

9-stage charging process for Lead Acid Batteries:

Battery Condition Analysis → De-Sulphation (if needed) → Soft-Start → Bulk Charge → Analysis 1 → Absorption → Analysis 2 → Equalization → Float Charge → (21 Days reset period)

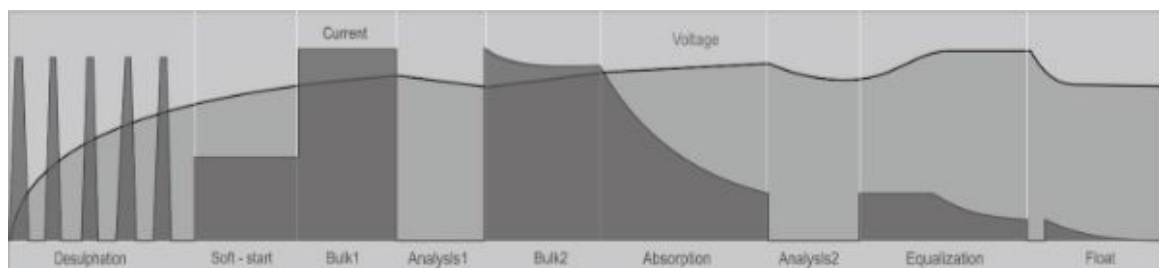

Fig -2

5- Stages for LiFePO4 Lithium Batteries

Soft-Start → Bulk Charge → Absorption (CV1+CV2) → Recharge → 21 Days reset period

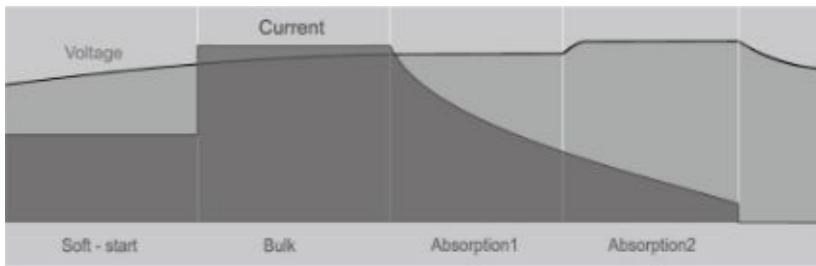

Fig-3

4.2 Charging processes

De-Sulphation:

In this stage rising voltage and high current pulses are applied to the battery to recover sulphated batteries.

De-sulphation current control: 25% of Bulk current delivered.

Soft start:

In this stage rising voltage and a maximum of 50% of bulk stage current is applied to the battery to begin the charging process.

Bulk charge:

In this stage rising voltage and maximum user defined current is applied to the battery.

- 5~150Amp adjustable for the F150

- 1-35Amp adjustable for the F35

Analysis-1:

In this stage the charger tests the battery in order to detect bad cells (only for Lead acid batteries). For abnormal cell detection results please refer to the troubleshooting section (8).

Absorption:

In this stage a constant voltage and tapering current is applied to the battery to ensure it reaches 80% state of charge.

Absorption stage voltages for each battery chemistry:

GEL Battery	14.1V
AGM Battery	14.4V
EFB Battery	14.5V
Flooded Battery	14.7V
LiFePO4	Absorption CV1 =14.0V
Battery	Absorption CV2 =14.4V

x2 for 24V mode (F35 only)

Analysis- 2: In this stage the charger tests the battery again in order to detect bad cells and high levels of sulphation (only

for Lead acid batteries).

Equalization: In this stage a higher voltage and low current is applied in order to balance the internal cells of the battery (only for Lead acid batteries).

Maximum equalization stage voltages for each battery chemistry:

AGM BATT	14.5V
EFB BATT	14.6V
Flooded BATT	15.5V
Equalization current control	15% of Bulk Current

x2 for 24V mode (F35 only)

Remarks: the interface will display **80~99%** charged during the Absorption and Equalization stage.

Float: Compatible only with Lead Acid batteries this stage is used for long term battery maintenance.

Float voltage: 13.6v

Remarks: the interface will display **100%** charged during the Float stage. If the voltage falls below 12.5V then the charger will automatically return to the **Bulk** mode.

LiFePo4 Recharge Stage: If the battery voltage falls below 12.8V the charger will automatically return to the **Bulk** mode.



If **AUTO-DETECT** is **ON**: the charger will automatically restart the charging process from where it was interrupted in case of a cut in AC power.

5 DIAGNOSTIC MODE (POWER SUPPLY MODE)

The charger will act as a stable, configurable power supply during vehicle diagnostics, repair and module programming.



Step 1: Press   to Enter or Exit this Mode.

Step 2: Press   to Select the desired parameters:
Battery Voltage; Output voltage, Maximum Output Current.

Step3: Press  to Start or Stop the mode.



Displayed values during diagnostics:

Load percentage: displays the load on the charger (%)

Current: displays the output current (A)

Voltage: displays the output voltage (V)

Watt: displays the output power (W)

Time: displays the duration

Output voltage control: 12~15v (x2 for 24V mode) adjustable



Output Current Control: 5~150Amp adjustable for the F150 units / 1-35Amp adjustable for the F35 units.

6 SHOWROOM MODE (POWER SUPPLY MODE)

Supply power to, and maintain the battery of vehicles in demonstration mode:



Step 1: Press   to Enter or Exit the mode.

Step 2: Press   to Select the desired parameter:
Battery Voltage; Output voltage, Output current.

Step 3: Press  to Start or Stop Showroom mode.



Display in Showroom mode:

Load percentage: displays the load on the charger (%)

Current: displays the output current (A)

Voltage: displays the output voltage (V)

Watt: displays the output power (W)

Time: displays the duration

Output voltage: Adjustable between 12.6 - 14.5v (x2 for 24V mode F35 only).

Output Current: Adjustable between 5 - 150Amp for the F150 and 1 - 35Amp for the F35.

7 TEST MODE:

Test both the vehicle's battery and starting system performance. (voltage and waveform)



Step 1: Press   to Enter or Exit this mode.

Step 2: Press   Select the correct voltage:

Step 3: Press  to Start or Stop the Testing process.

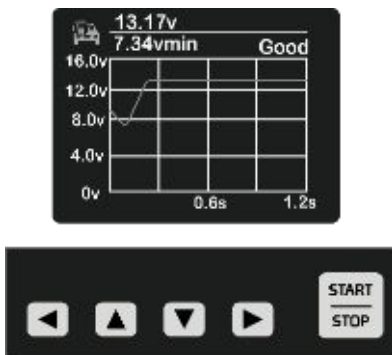

Display in Test mode:

Battery voltage: displays the vehicle's battery voltage (V)

Starting System: displays the voltage waveform and minimum voltage

Test Result: Excellent, Good, needs to be recharged, Bad

8 ABNORMAL DISPLAY AND TROUBLE SHOOTING

Abnormal condition	Possible cause	Suggested solution
No battery detected	Loose connection	Check the battery and terminal connections
Battery short circuit	Incorrect connection	Check the battery and cables connections.
Inverse battery connections	Incorrect connection	Reverse the polarity of the connection to the battery
Voltage is too low	If the Battery voltage is less than 2-4V, the charger will not start to recharge the battery automatically	Press and hold  for 3 seconds to force the charging process to start (Check the connections before activating this function)
Voltage is too high	12V batt. set with the 24V mode	Change to the correct 12/24V mode
Battery bad cell protection	Battery has failed	Replace the battery
Over-temperature protection	The charger needs to be checked	Contact your distributor
Over voltage control protection	The charger needs to be checked	Contact your distributor
Over current control protection	The charger needs to be checked	Contact your distributor
Bad battery (in Test mode)	Battery is short circuited or has failed	Replace the battery
Need to charge (in Test mode)	Deeply discharged or sulphated battery	Use the Charge mode to recharge the battery

9 SPECIFICATION

Input voltage:	220-240Vac 50/60Hz 0.42A Max.
Rated output:	12 24Vdc 35A for F35; 12V Peak- 150A, Continuous 100A for F150.
Battery type:	Lead acid (Flooded, AGM, EFB, GEL.) or lithium (LiFePO4) starter batteries.
Suitable for Battery size:	20 Ah to 1200 Ah.
Operating Environmental:	-10~40°C, 0-90% RH.
Storage environmental:	-20~85°C, 0-90% RH.
Input cable size:	1.5mm ² 3C 75°C WITH 3Pin VDE Plug plus IEC-60320-C19.
Output cable size:	3meter 8mm ² 105°C with clamps for F35. 3meter 25mm ² 105°C with clamps for F150.
Net weight:	Approx. 6.0 Kg for F35; Approx. 9.0 Kg for F150.
Safety Standard :	EN 60335-1, EN 60335-2-29, EMC Standards: EN55014

Dimensions

F35 (Lx Wx H: 257*243*100mm)

F150 (Lx Wx H: 312*303*100mm)

Installation dimension exemple on F150:

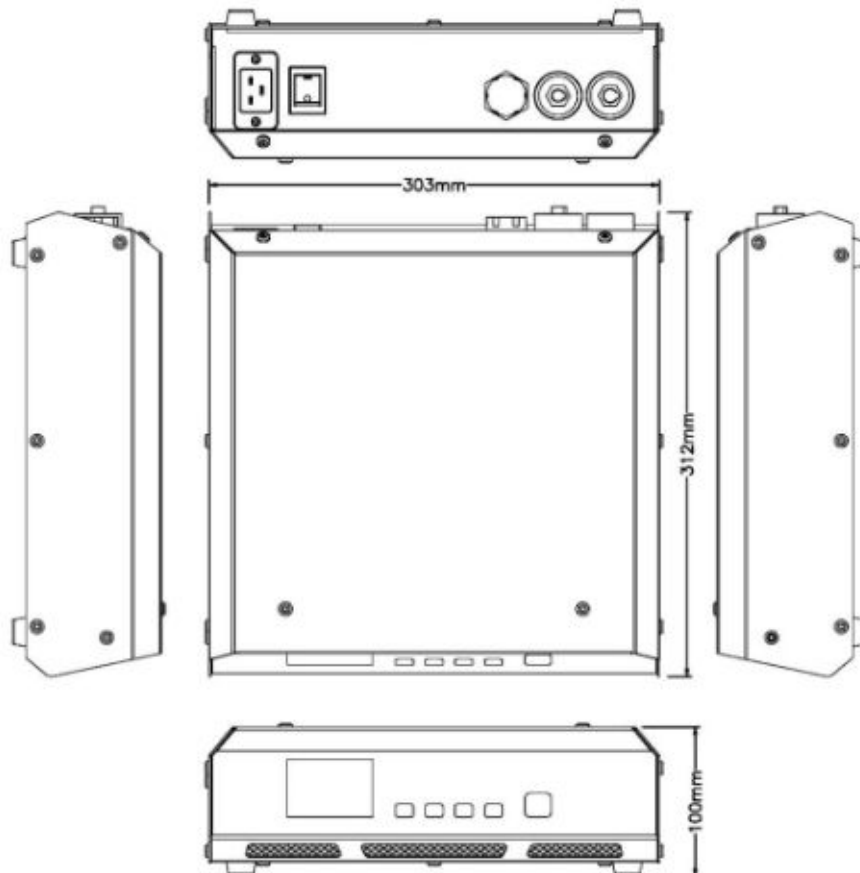

Fig-4

10 WARRANTY INFORMATION:

The warranty of this unit depends on the conditions granted by your retailer. The manufacturer shall have no liability whatsoever at any time for any warranty, personal injury or property damage. Transport is never included.

Please dispose of the packaging in a responsible manner. It should be recycled by your local amenity or placed in appropriate recycling bins. Never dispose of electrical equipment or batteries in your domestic waste. Have them recycled by your retailer or your local amenity.